

1750mm dia. Ocean Buoy

POSEIDON-1750



POSEIDON-1750
Wreck Marking Buoy

Sealite have a range of mooring chains & accessories - ask your representative today how we can supply your complete mooring solution

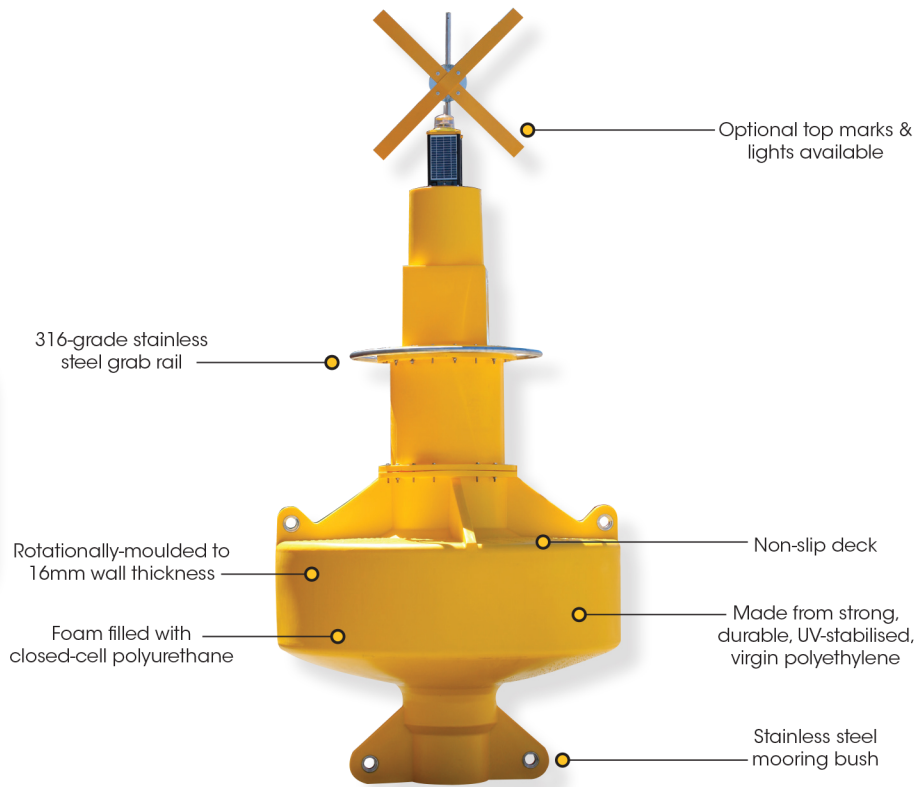

The Sealite Advantage

- High visibility red, green, white or yellow as per IALA recommendations
- 3 part product: floatation section, mid section & top section
- Individual colouration of each section to suit IALA colour/configuration recommendations
- Excellent buoyancy & stability
- Easy to deploy & service
- No painting, ever
- Cost effective & environmentally friendly

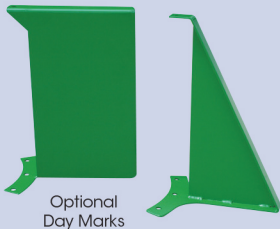

Sealite buoy products are made from recyclable materials. As a service to customers, individual components and products at the end of their service life may be returned to Sealite for recycling.

The Sealite POSEIDON-1750 Buoy is manufactured from UV-stabilised, virgin polyethylene and has been specifically designed to withstand the harsh marine environment, and operate reliably with minimal maintenance.

Ports worldwide are realising the advantages of polyethylene buoys over traditional steel models. The colour pigment is added to the polyethylene during the moulding process, which means that the buoy never requires painting.

The polyethylene material also inhibits marine growth, so the buoy requires cleaning less often than steel types.

Significant advantages of the polyethylene buoy allow the interval between servicing to be far greater and users continually report major cost savings.

The POSEIDON-1750 is constructed from 3 parts ensuring ease of deployment and servicing. The float section incorporates two large lifting and mooring points, interconnected by 316-grade stainless steel tie-bars to provide greater strength. The mid-section may be supplied with a large secondary battery enclosure, whilst the top section is designed to carry the buoy's primary payload.



1750mm dia. Ocean Buoy

POSEIDON-1750

The float section is internally cross-braced (■) using stainless steel braces joining each mooring eye to the lifting eye. This ensures mooring and lifting stresses are evenly shared across the structure.

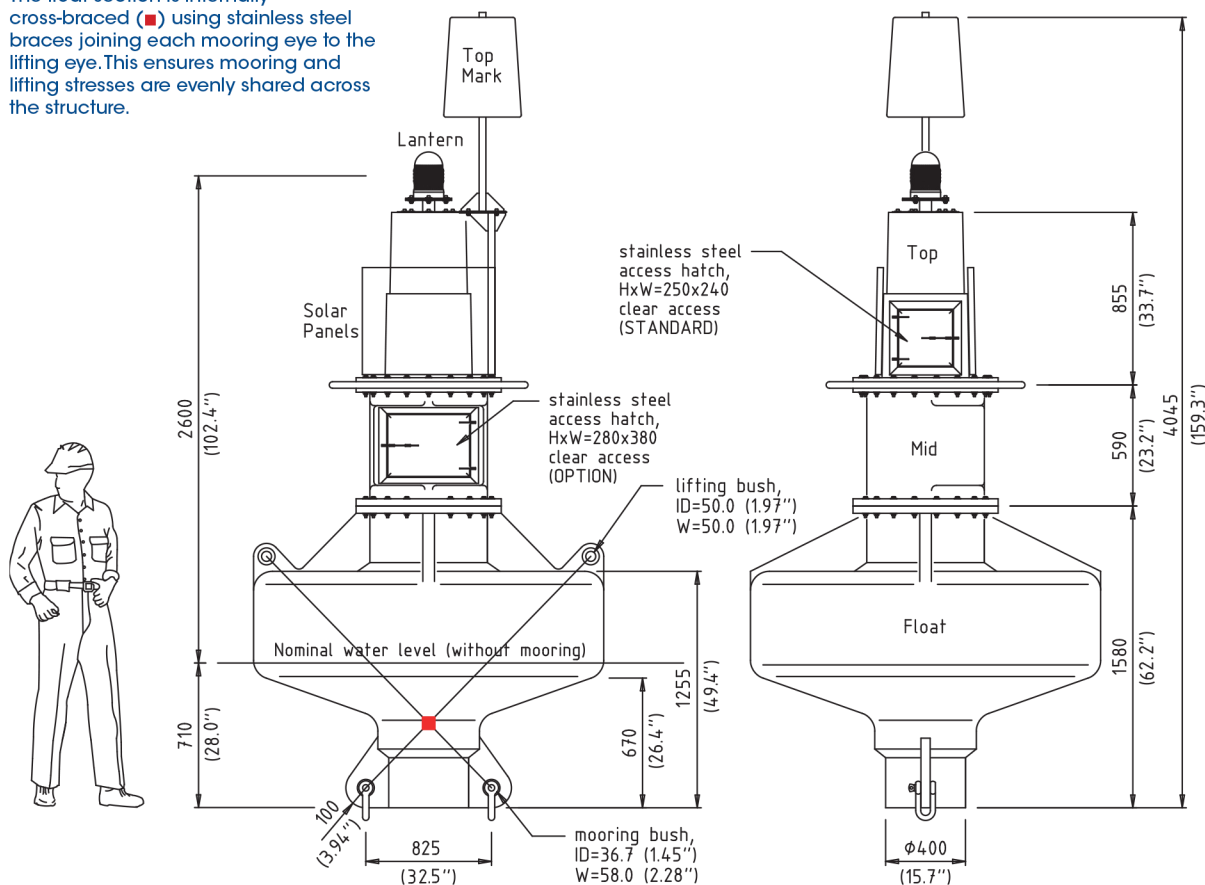

SPECIFICATIONS * POSEIDON-1750

General Characteristics

Available Colours
Focal Plane Height (mm/inches)
Total Float Volume (ltrs/US gallon)
Nominal Freeboard (mm/inches)
Nominal Draft (mm/inches)
Reserve Buoyancy (kgs/lbs)
Maximum Mooring Load (kgs/lbs)
Draft, Maximum (mm/inches)
Freeboard, Minimum (mm/inches)
Safe Working Load, 1pt (kgs/lbs)
Safe Working Load, 2pt (kgs/lbs)
Submergence (kg/cm, lb/inches)
Visual Area (m²/ft²)

Red, Green, White, Yellow as per IALA Recommendations
2600 / 101.8 (standard), 3090 / 121⁵/₈ (with spacer)
1815 / 480
545 / 21.5
710 / 28
600 / 1323
600 / 1323
955 / 37.6
300 / 11.8
2300 / 5070
3250 / 7165
24.5 / 137
1.9 / 20.4

Physical Characteristics

Material

Rotationally-moulded UV-stabilised virgin polyethylene, internal 316-grade stainless steel bracing, 316-grade stainless steel fittings, slip resistance platform

Wall Thickness (mm/inches)

16 / ⁵/₈ (float section)

Ballast (kg/lbs)

150 / 330 internal concrete

Filling

Closed-cell polyurethane foam (float section)

Height (mm/inches)

4045 / 159

Width (mm/inches)

1750 / 68⁷/₈

Mass (kg/lbs)

428 / 944

Radar Reflector

Echomax

Product Life Expectancy

>20 years

Certifications

IALA
Quality Assurance

Surface colours compliant to IALA E-108
ISO9001:2008

Intellectual Property

Trademarks

SEALITE® is a registered trademark of Sealite Pty Ltd

Warranty *

5 years

Lantern Options

Sealite SL-C310, SL-C410, SL-C415, SL-C420, SL-125 Series or SL-155 Series

Options Available

- Mould-in graphics
- Day marks
- Monitoring Systems (AIS, GSM)



* Specifications subject to change or variation without notice
* Subject to standard terms and conditions